



KONSTRUKTIONSBÄNDER OHNE UNTERLEGSCHLEIFE MIT FLACHEN FLÜGELN

12-1-3309

| | |
|-------------------|-------|
| A | 80 mm |
| Ausführung | Typ 2 |

| | |
|-----------------------------------|-------------|
| Material | Stahl |
| Gewicht (g) | 76 g |
| B | 48 mm |
| C | 2 mm |
| E (Gelenkteile oder Dicke) | 40 mm |
| D (Durchmesser) | 5.8 |
| Dekor | unbehandelt |

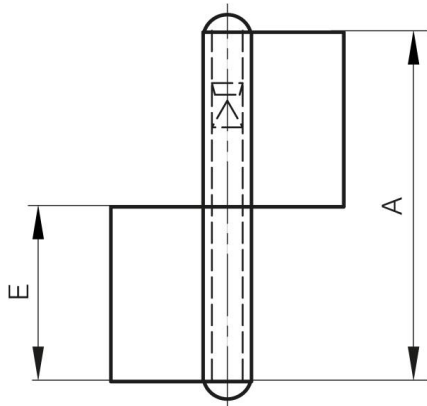

12-1-3308 & 12-1-3310

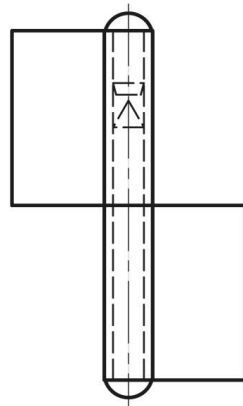

12-1-3307 & 12-1-3309

