



VIERKANTSCHLÖSSER 4X4

16-7-3289

| | |
|--------------------|---------|
| A | 85 mm |
| Material | Stahl |
| Gewicht (g) | 45 g |
| B | 16.5 mm |

| | |
|-----------------------------------|----------|
| C | 7.7 mm |
| S (Lochdurchmesser) | 3.6 mm |
| E (Gelenkteile oder Dicke) | 3 mm |
| D (Durchmesser) | 3.5 |
| F (Abstand) | 23 mm |
| G (Abstand) | 67 mm |
| H (Höhe oder Startlöcher) | 16 mm |
| Dekor | verzinkt |

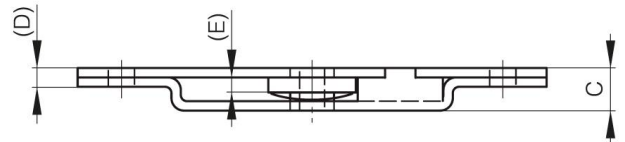
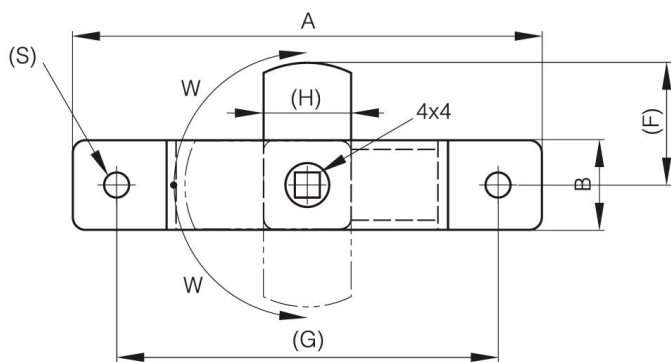

| | |
|-----------------------|-----------|
| W (Drehwinkel) | 90° Degré |
|-----------------------|-----------|