



VERSCHLUSS MIT ARRETIERUNG UND RÜCKSTELLFEDER A

16-1-4034

Schwerlastausführung.
Arretierung in geöffneter Position.

A	152 mm
Material	Stahl

Gewicht (g)	340 g
B	75 mm
S (Lochdurchmesser)	9 mm
H (Höhe oder Startlöcher)	34 mm
Dekor	verzinkt

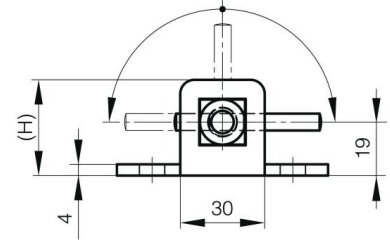
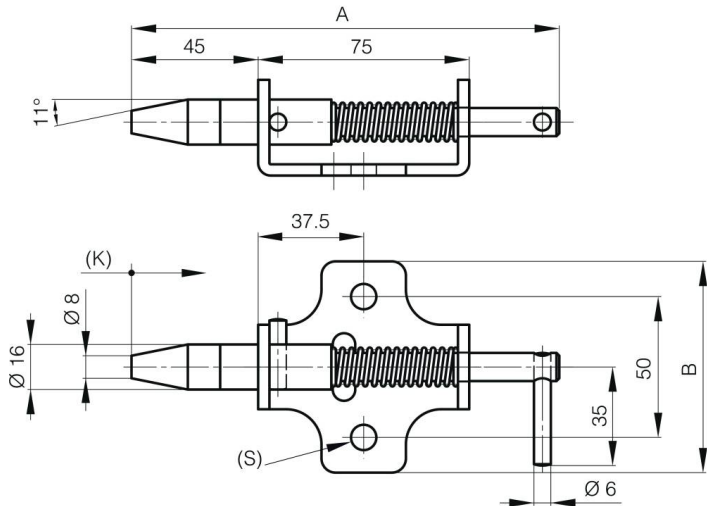

K	20 mm
----------	-------