



## **CERNIERE A MOLLA - PROFILO ALLUMINIO 0,70 NM - DIAMETRO 13**

**72-1-4218**

Forza della molla di apertura: M(0°): 0,7 Nm / M(90°): 0,45 Nm / M(180°): 0,23 Nm Forza della molla di chiusura: M(0°): 0,23 Nm / M(90°): 0,45 Nm / M(180°): 0,7 Nm Altre 3 versioni disponibili: oscillazione libera, con frizione o con meccanismo di arresto.

<b>A</b>	67 mm
----------	-------

<b>Nota</b>	primavera di apertura
<b>Materiale</b>	6060 T5 alluminio
<b>Peso (g)</b>	68 g
<b>B</b>	55 mm
<b>C</b>	4.5 mm
<b>D</b>	13
<b>Finitura</b>	anodizzato chiaro

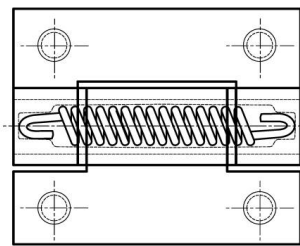
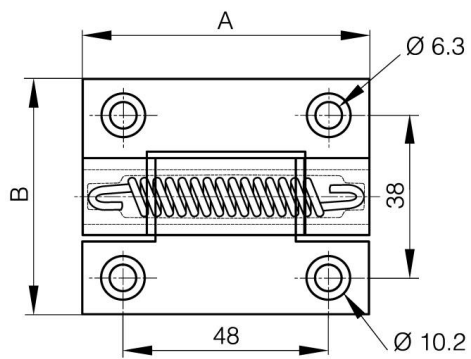

72-1-4322 & 72-1-4325  
72-1-4326 & 72-1-4335

